



Welcome Pack  
Stolen Vehicle Recovery

**Tracker S5+**  
Immobiliser

Stolen Vehicle Recovery

# Welcome Pack

# Tracker S5+

Immobiliser

Tracker™



# Retrieve your vehicle with ease should it ever be stolen

**To ensure that the police are able to navigate straight to your vehicle, there are a few things you MUST do:**

- Tracker Driver Tags- you should immediately attach a tag each to both sets of keys
- Keep your Tracker membership card with you at all times.
- Store your Tracker registration document somewhere safe.
- Double check that your Tracker registration information is correct.
- Provide a telephone number and an email address so we can contact you.
- And relax! Your vehicle is now covered in the event of theft.

If you require additional information about your Tracker system, please feel free to contact our Customer Service team on 0808 509 0909 or visit our website at [www.tracker.co.uk](http://www.tracker.co.uk)

A photograph of a car covered in a red protective cover, parked in a concrete parking garage. The car is positioned in the lower-left quadrant of the frame. The background shows the structure of the garage with pipes and fluorescent lights. A white diagonal line separates the image from the text on the right.

# What to do if your vehicle is ever stolen

- ✓ Immediately report the theft to the police
- ✓ Obtain a Crime Reference Number
- ✓ Call Tracker 24hr Control Room on:

**+44 (0) 800 911 900\***

Please ensure you have the following information to hand before call Tracker 24hr Control Room:

- Vehicle registration number
- Your Tracker system serial number
- Crime Reference Number

\*Calls made from outside of the UK may be charged.

# Tracker Touch

## App Set Up Guide

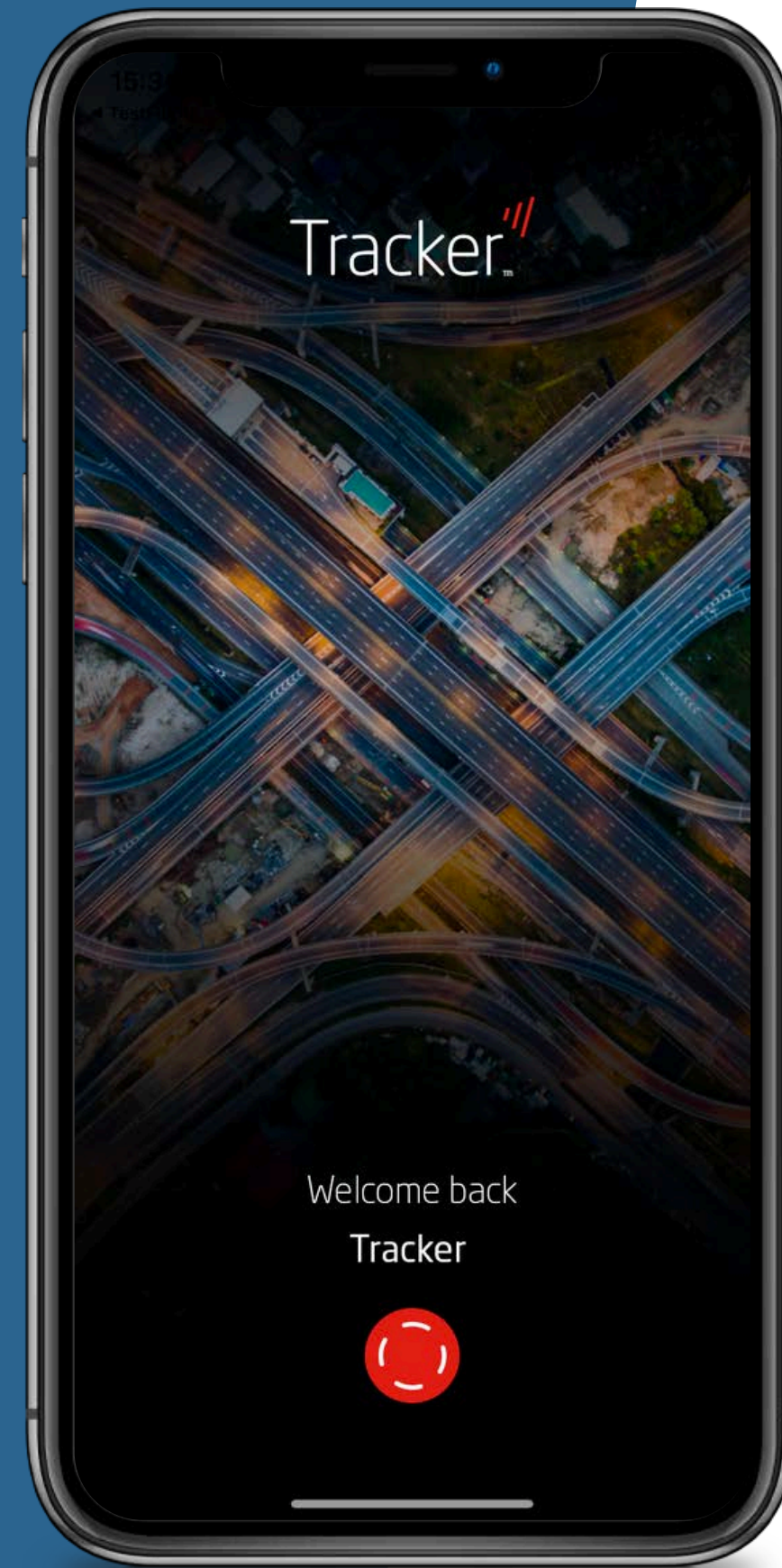

Tracker™

# Tracker Touch

## App Set Up Guide

You should have already downloaded our Tracker Touch app, if you haven't, it is available to download from the App store or Google Play.

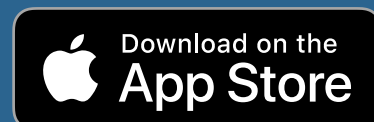

Tracker™

# Simple Set Up

Before you can start using Tracker Touch there are a couple of important steps to run through to ensure your app is connected to your Tracker device.

## You will need:

- Tracker Touch app - downloaded to your smart phone
- Security Token - you can find this in your welcome email
- Serial Number - this can be found in the Registration Document which is sent as an attachment in your welcome email

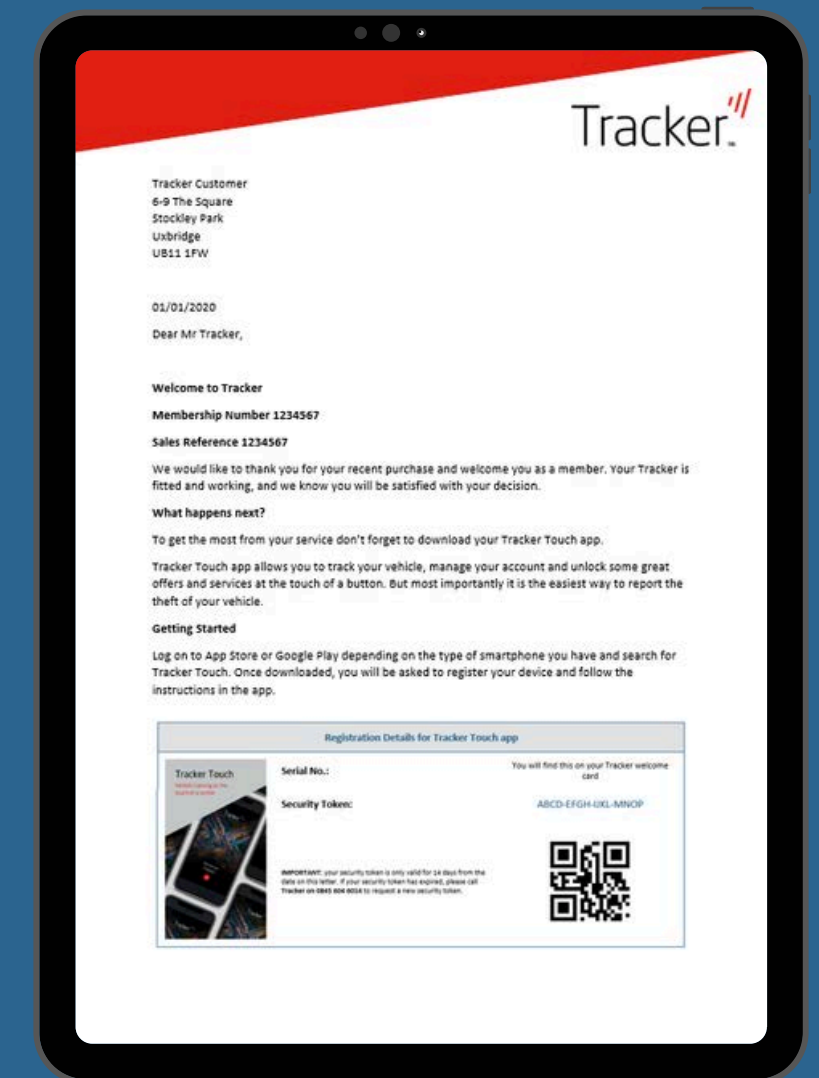

# Registration

## New to Tracker Touch?

### Step 1: Connecting your Tracker device to your phone

When you open the Tracker Touch app you will be asked to enter:

- Serial Number - this can be found in the Registration Document which is sent as an attachment in your welcome email
- Security Token - you can find this in your welcome email/letter
- **Please note:** These fields are case sensitive so please enter all characters as shown
- Select **REGISTER THIS DEVICE**

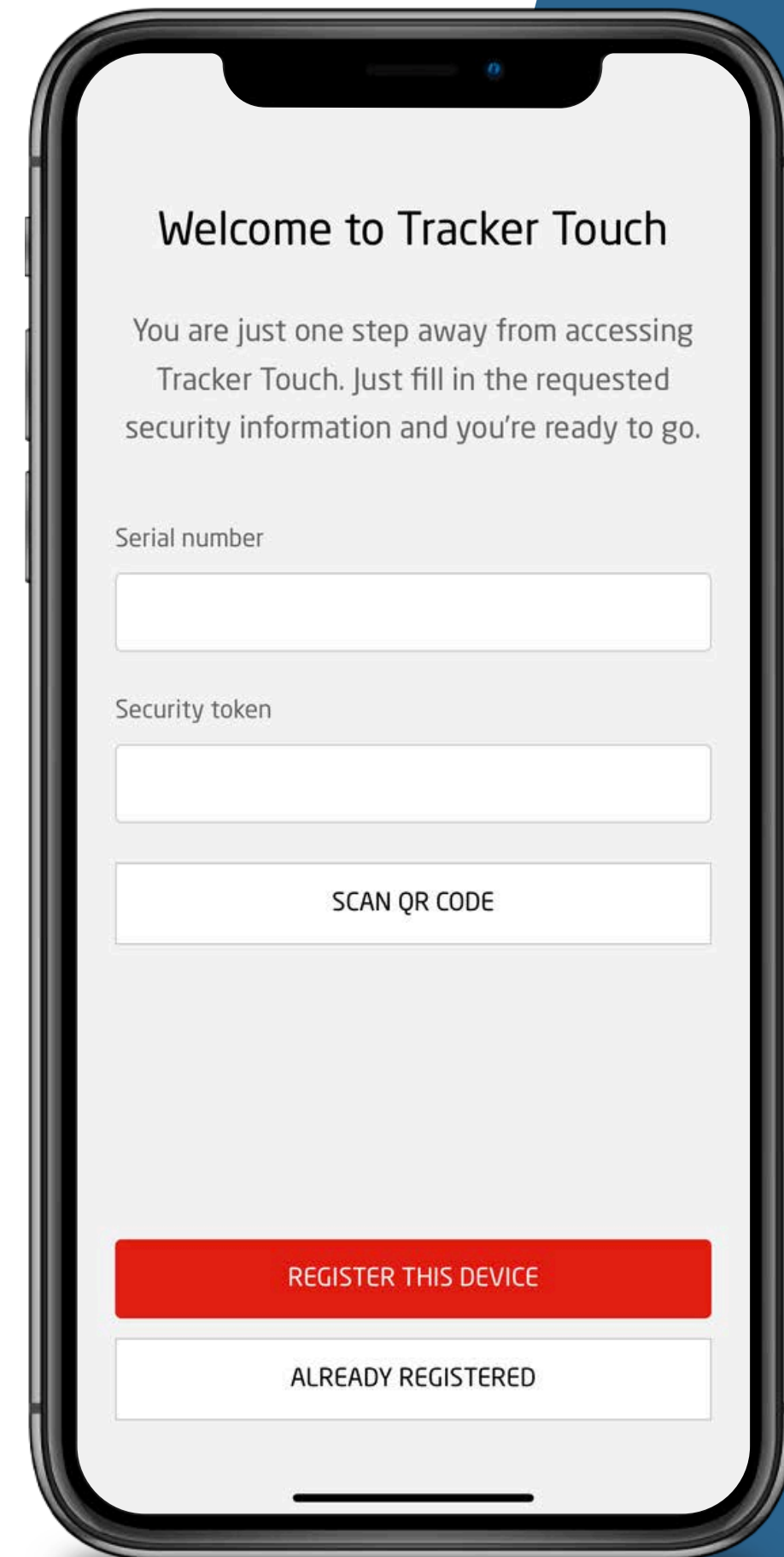
A screenshot of a smartphone displaying the Tracker Touch app registration screen. The screen has a white background with black text. At the top, it says "Welcome to Tracker Touch". Below that, a message reads: "You are just one step away from accessing Tracker Touch. Just fill in the requested security information and you're ready to go." There are two input fields: "Serial number" and "Security token". Below these fields is a button labeled "SCAN QR CODE". At the bottom, there are two buttons: a red button labeled "REGISTER THIS DEVICE" and a white button labeled "ALREADY REGISTERED".

Welcome to Tracker Touch

You are just one step away from accessing Tracker Touch. Just fill in the requested security information and you're ready to go.

Serial number

Security token

SCAN QR CODE

REGISTER THIS DEVICE

ALREADY REGISTERED

# Registration

## Step 2: Creating a Login Account

Once you have successfully linked your phone to your Tracker device you will be asked to create an account using an email address and setting a password.

Once you have entered an email address and password, select **CREATE ACCOUNT**

You are now successfully logged into the Tracker Touch app!

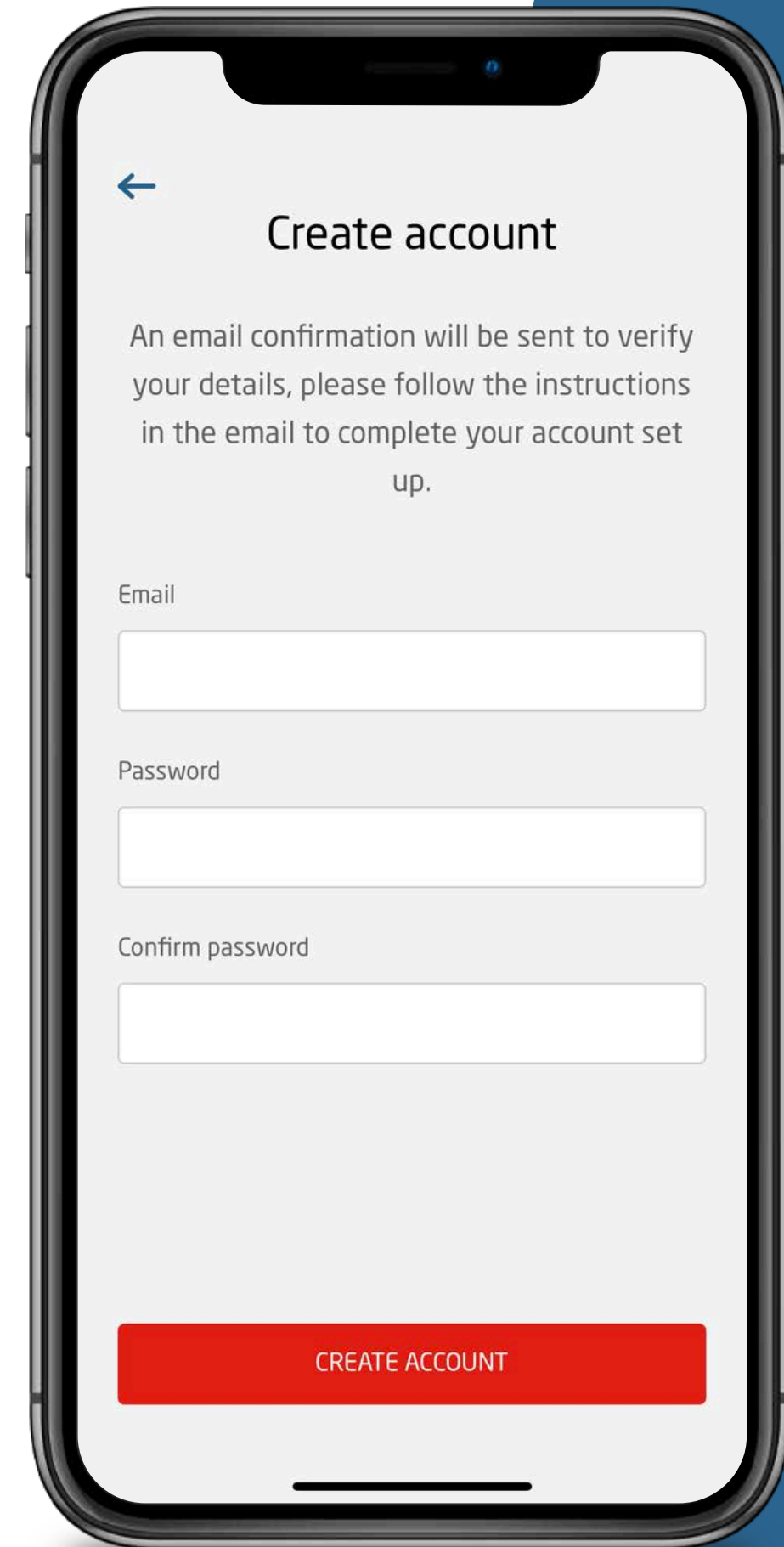

The image shows a smartphone screen with the 'Create account' registration form. At the top left is a back arrow icon. The title 'Create account' is centered at the top. Below the title is a paragraph of text: 'An email confirmation will be sent to verify your details, please follow the instructions in the email to complete your account set up.' There are three input fields: 'Email', 'Password', and 'Confirm password'. At the bottom of the screen is a red button labeled 'CREATE ACCOUNT'.

# Already Registered?

How to log back into your Tracker Touch app

For customers with **one** registered vehicle

1. Select **ALREADY REGISTERED**
2. Enter your registered email address and password
3. Select **SIGN IN**
4. **Add an image** of your vehicle from your camera roll
5. Select **MANAGE MY VEHICLE**
6. You are now successfully logged into the Tracker Touch app!

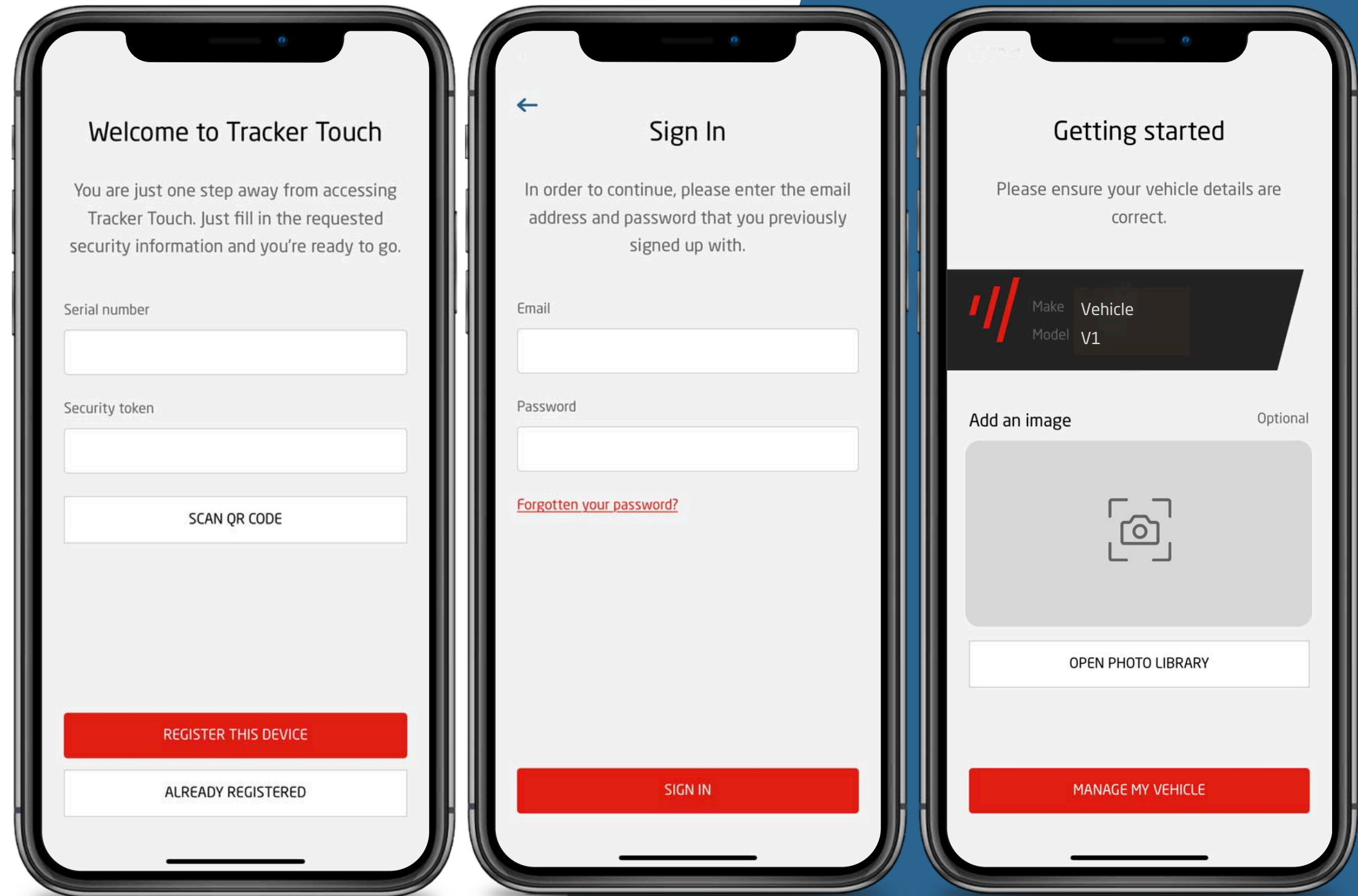

# Already Registered?

How to connect additional vehicles on your account to the Tracker Touch app

For customers with **multiple** registered vehicles

1. Select **ALREADY REGISTERED**
2. Enter your registered email and password
3. Select **SIGN IN**
4. All of your vehicles that have previously been registered within the app will appear, select the vehicles you wish to manage in the app
5. Select **CONNECT**
6. **Add an image** of your pride and joy from your camera roll
7. Select **MANAGE MY VEHICLE**
8. You are now successfully logged into the Tracker Touch app!

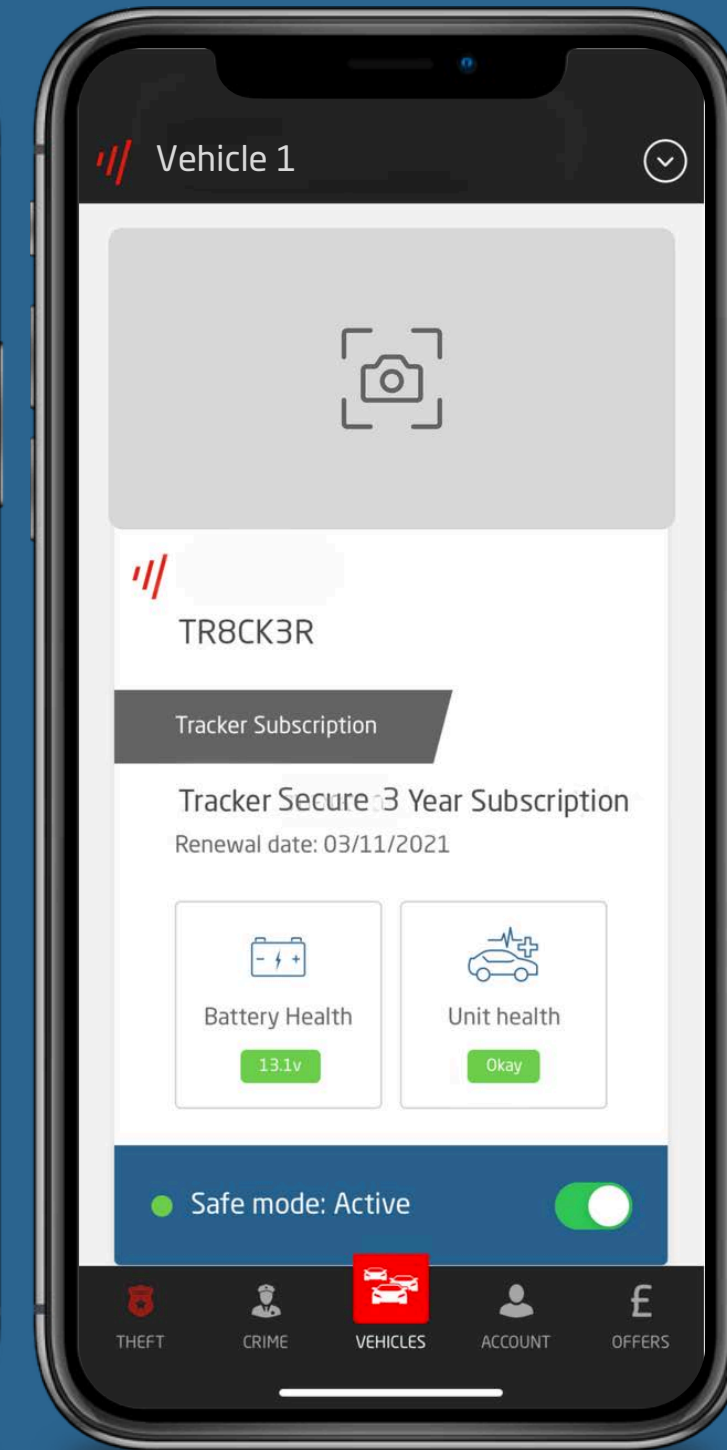
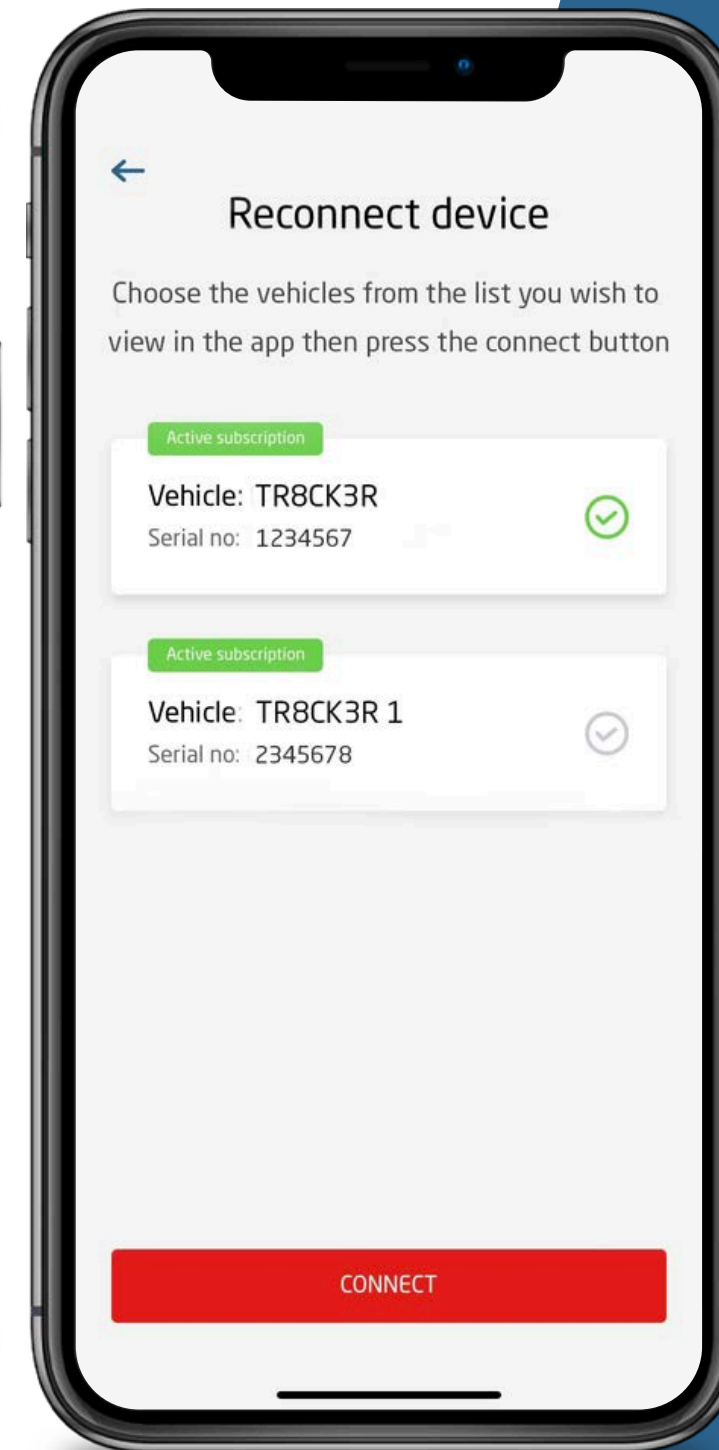
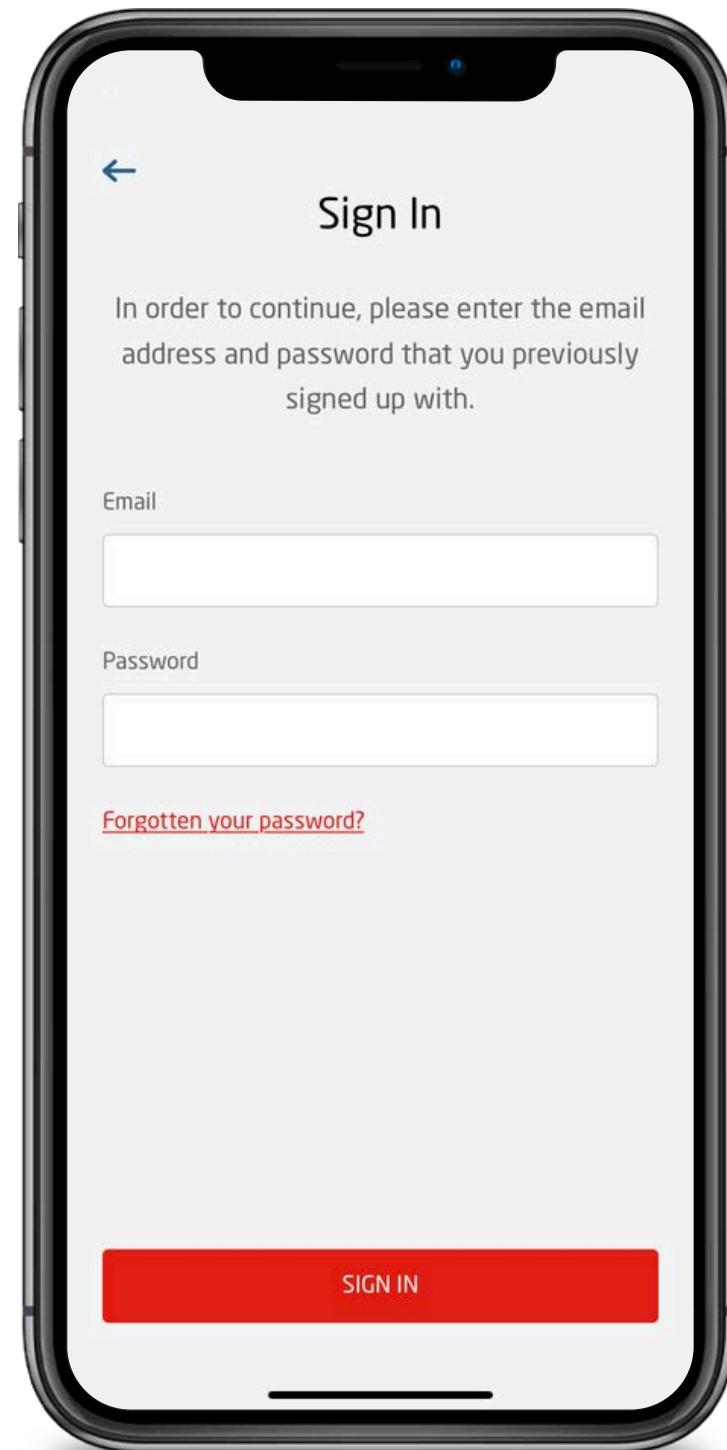

# Tracker S5+ Immobiliser

Find out more about your Tracker product

Tracker<sup>TM</sup> 

# How it works

Our devices are operated by all of the UK's police forces. Most of our devices use Very High Frequency (VHF) technology, the police can track the stolen vehicle even if it is hidden in a garage or shipping container.

**With a Tracker system installed, your vehicle is in safe hands**

## Tracker S5+ Immobiliser

The **Tracker S5+ Immobiliser** is designed to prevent a vehicle from being driven without authorisation. It provides discreet, high-level protection against even the most professional and determined thieves.

### How it works

The system integrates seamlessly with secure **Driver Validation Tags**, ensuring that only authorised drivers can operate the vehicle. When the ignition is switched off, the immobiliser **automatically arms**, protecting the vehicle without requiring any action from the driver.

To drive the vehicle, a valid **Driver Tag** must be within range. Each tag transmits a uniquely encrypted signal that is instantly recognised by the Tracker device. Once authorisation is confirmed, the system **automatically disarms**, allowing the vehicle to be driven normally. If a valid Driver Tag is not detected, the vehicle remains **securely immobilised**. The system prevents the relay from energising, ensuring the vehicle cannot be driven.

### Theft Response and Recovery Support

If unauthorised activity or theft is detected, the customer is alerted by SMS.

If the vehicle is stolen, the customer should report the theft to the police and then contact the 24/7 Secure Operating Centre with the Crime Reference Number. This enables a rapid response and supports police tracking to help recover the vehicle as quickly as possible.

### Features of Tracker S5+ Immobiliser

- **Advanced VHF tracking** that continues to operate even when a vehicle is hidden in metal containers, lock-ups, or underground car parks
- **Unique tracking technology** that remains effective even in the presence of GPS/GSM signal jammers
- **Automatic immobilisation** when a valid Driver Tag is not detected
- **Motion and tamper alerts** for added reassurance
- **Remote override capability** via the Secure Operating Centre
- **Remote immobilisation capability** via the Secure Operating Centre in the event of theft
- **24/7 assistance** from the Secure Operating Centre
- **Backup battery protection** to maintain security if vehicle power is interrupted
- **Nationwide support** in partnership with UK police forces
- **Stolen vehicle tracking across Europe** for extended peace of mind
- **Thatcham S5 and CAT2E accredited** - recognised security standards

# Product Care

## Battery back-up for your S5+ Immobiliser

Your tracking unit includes a non-rechargeable back-up battery, allowing it to continue operating if the main vehicle battery is disconnected. Backup duration is limited and depends on how often and how long the vehicle battery has been disconnected over the product's lifetime, such as during servicing or theft.

### What to do when your vehicle is booked in for Service/Repair:

- ✓ When servicing your vehicle, advise the technician to keep vehicle battery disconnection time to a minimum.
- ✓ Please inform the technician that an immobiliser is fitted. **To prevent the vehicle from being immobilised, ensure the car key and Driver Tags are kept together** when starting the vehicle.
- ✓ If your vehicle battery is disconnected, an alert will be generated. You must inform Tracker prior to battery disconnection to avoid any false alerts.
- ✓ If the non-rechargeable back-up battery becomes flat a chargeable service call will be required.

## Replacing the Battery in your Tracker Driver Tag

### When to replace the battery

- Each Driver Tag uses a **CR2032 battery**
- When the battery is running low, the LED on the tag will flash to let you know it is time to change it

### How to replace your Driver Tag battery

- **The tag casing separates into two halves.**
- To separate the two halves, locate the opening recess. Using a **thin flat-head screwdriver**, gently insert it into the slot and carefully prise the case apart (A)
- Carefully push the old battery out from the gaps in its holder and insert the new battery in its place (B). Tag contains **CR2032 battery**.
- Insert the new CR2032 battery, making sure the "+" symbol on the battery matches the "+" symbol inside the case
- **When refitting the case:**
- Position the two halves together first and Then gently press the top closed until it clicks into place

### When should I replace the battery in the driver tag?

- Every 12 months
- When the LED flashes on the driver tag
- If you are experiencing any false alerts

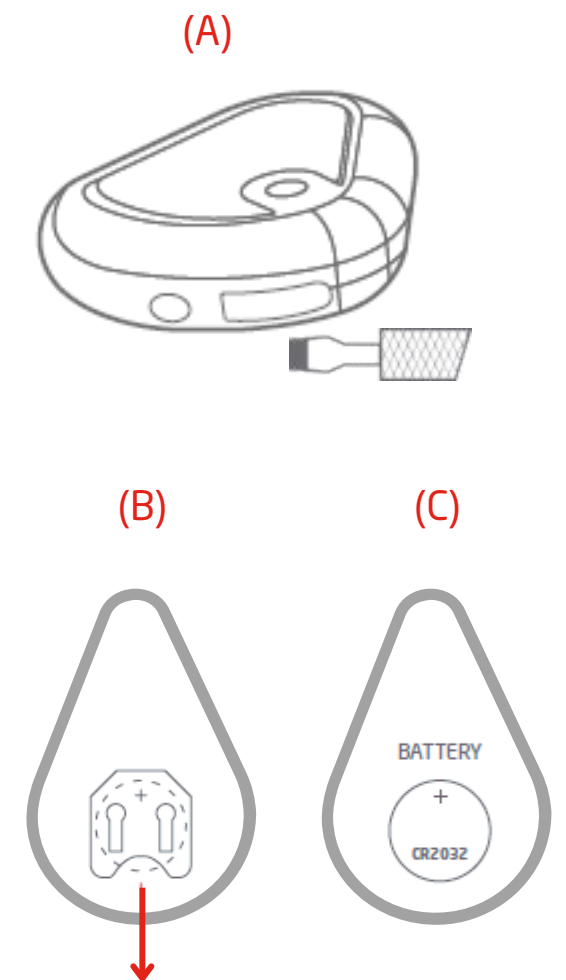

# Troubleshooting

## Tracker S5+ Immobiliser Not Disarming

If your Tracker S5+ Immobiliser **does not disarm** while a valid Driver Tag is nearby, please try the checks below.

### 1. Check the Driver Tag is awake

- To preserve battery life, the Driver Tag enters sleep mode after around 10 minutes without movement.
- Simply pick up or gently move the tag to wake it.
- Once awake, it will begin transmitting again and the system should disarm if the tag is within range.

### 2. Try your spare Driver Tag

- If available, try using your spare Driver Tag.
- If the system disarms successfully, the immobiliser is working correctly.
- This suggests the original tag may need attention, such as a low battery.

### 3. Replace the Driver Tag battery

- The system may not disarm if the Driver Tag battery is too low.
- Replace the battery by following the steps in the [Tag Battery Replacement](#) section.
- Once replaced, test the tag again.

**Important:** Remove any protective film before fitting the new battery.

### 4. Requesting a Remote Override via the Secure Operating Centre

- Where possible, please try troubleshooting steps 1–3 before contacting the Secure Operating Centre.
- To request a remote override and restore vehicle mobility, call the [Secure Operating Centre](#) on [0800 911900](#).
- Please note that the override command provides a **30-minute window** to start the vehicle. Once started, the journey must be completed within the same ignition cycle.
- If the ignition is switched off, the vehicle will not restart and a **new override command** will be required.

### What to Do if a Driver Tag Is Lost or Stolen

- If your Driver Tags are lost or stolen, contact the [Customer Service Support Team](#) on [0808 5090909](#) as soon as possible to order replacements.
- Up to **five additional Driver Tags** can be purchased, and charges apply.

### Driver Tag Battery Care

To ensure reliable operation, monitor the Driver Tag battery regularly. Under normal use, replace the battery every 12 months, or sooner if the system indicates that replacement is required.

# Tracker Touch

## App Features

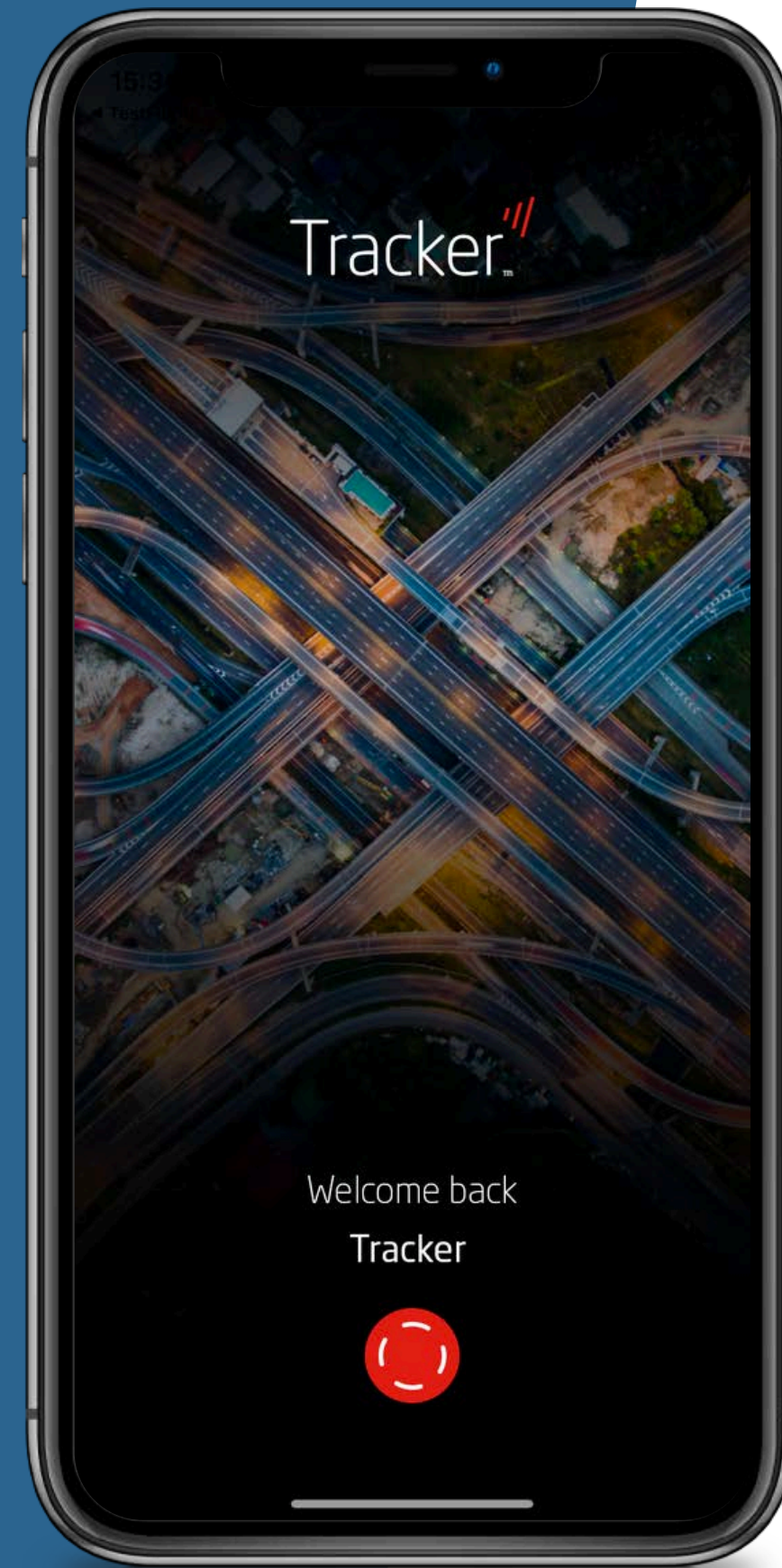

Tracker™

# App Features

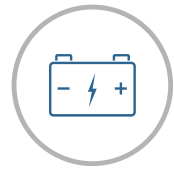

## Battery Health

Keep an eye on the health of your vehicle's battery so you can avoid unnecessary breakdowns.



## System Health

Monitor the health of your Tracker™ system at any time.



## Geofence Management

As an additional security layer, you can set multiple Geofence Areas by defining custom perimeters such as your home and work. If your vehicle breaches an activated perimeter, you will receive an instant alert.

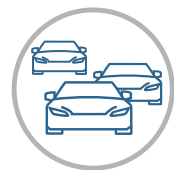

## Multi - Vehicle

Tracker Touch allows you to register and view multiple vehicles on a single log-in, enabling you to manage all your vehicles in one place.

Within Vehicles, you have an overview of the vehicle you currently have selected.

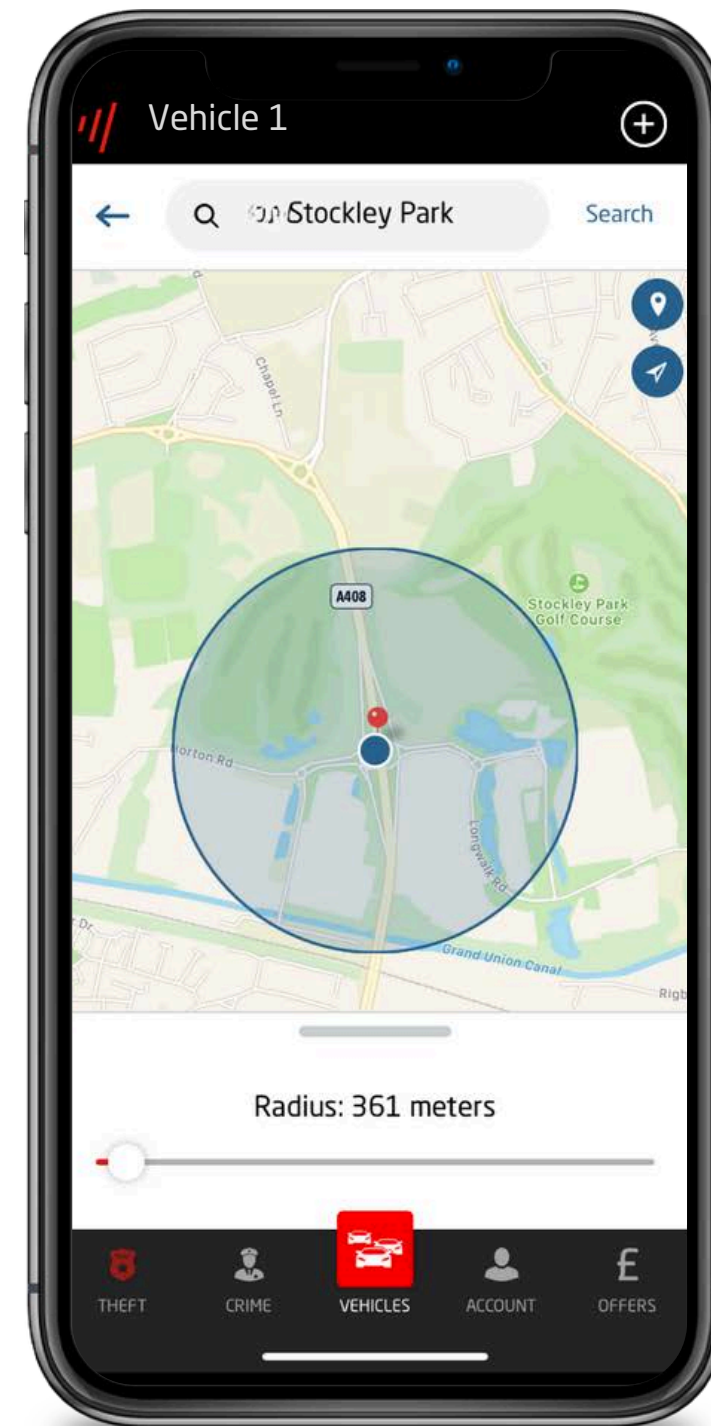
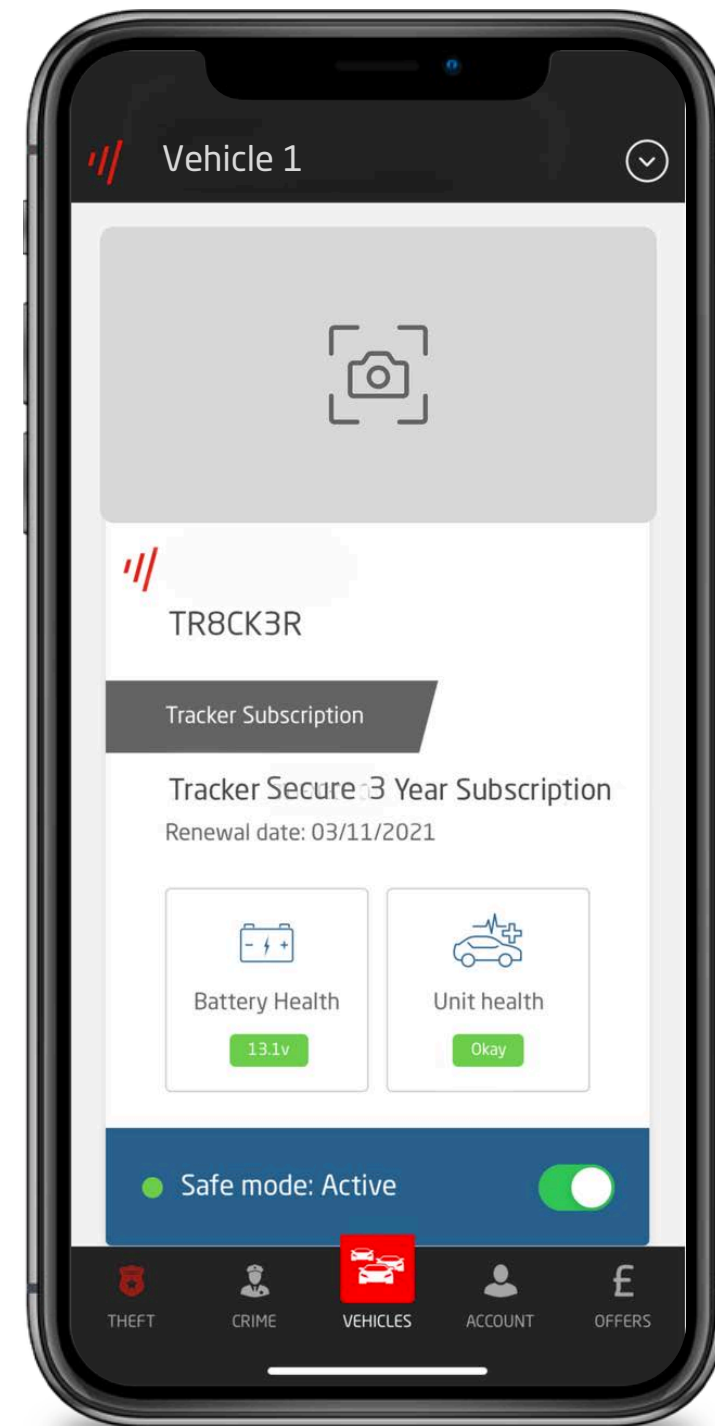

## Emergency Contacts

Be sure to set at least two emergency contact numbers. These numbers will be contacted with any alerts.



## Find My Vehicle

Forgotten where you parked? You can use the Tracker Touch app to find your car. Using the "Show on map" feature, the vehicle location can be displayed on your preferred map.

**Please note:** In the rare instance that your map does not show an accurate location due to poor GPS signal, be rest assured our patented VHF technology will always be active in the unfortunate event of theft.

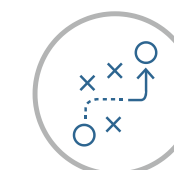

## Trip Tracker

All your travels are tracked and documented within the Tracker Touch app, so you can share the routes you've taken and even review detailed information, such as distance and time.



## Update Image

Tracker Touch allows you to add an image of your vehicle. Use this feature to update your vehicle photo.

# Safe Mode

Use Safe Mode to quickly activate an Alert service for your vehicle, if your vehicle is moved while the Alert is set to 'Active' you will be notified. You can use the Safe Mode toggle to activate and deactivate the Alert within the Vehicles page.



To activate or deactivate a Safe Mode slide the toggle on and off

Activated  Deactivated 

Please note: Safe Mode should only be set to active when the vehicle is stationary as regular alerts will be generated when the vehicle is being driven.

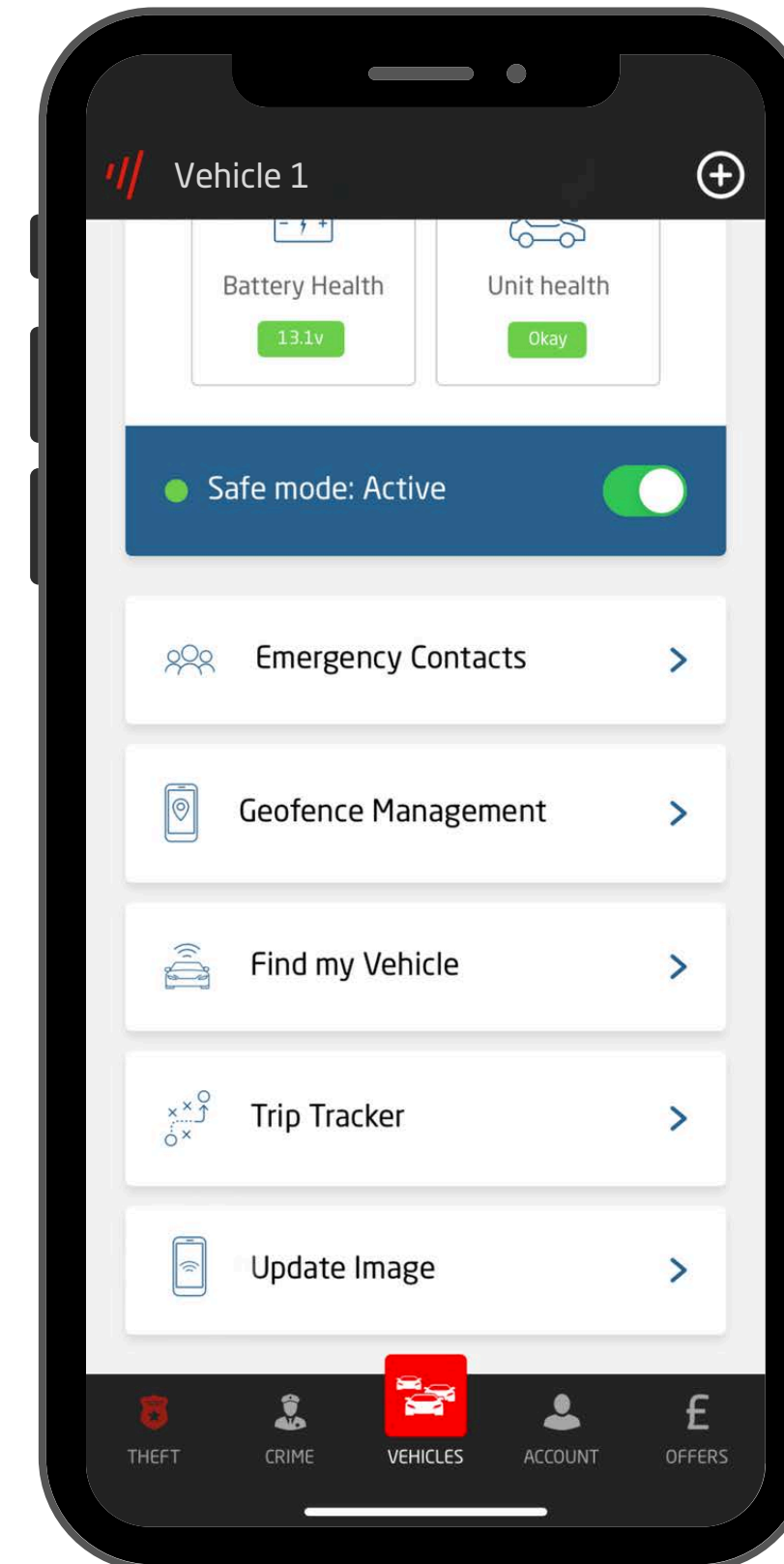

# Multi-Vehicle

Tracker Touch allows you to manage up to five vehicles within a single log in.

## How to add an additional vehicle

1. To add an additional vehicle to your app, select the **+** button in the top right hand corner of the screen
2. Enter the **Serial Number** and **Security Token** of your additional device
3. Select **Register This Device**
4. All registered vehicles will show on the drop down

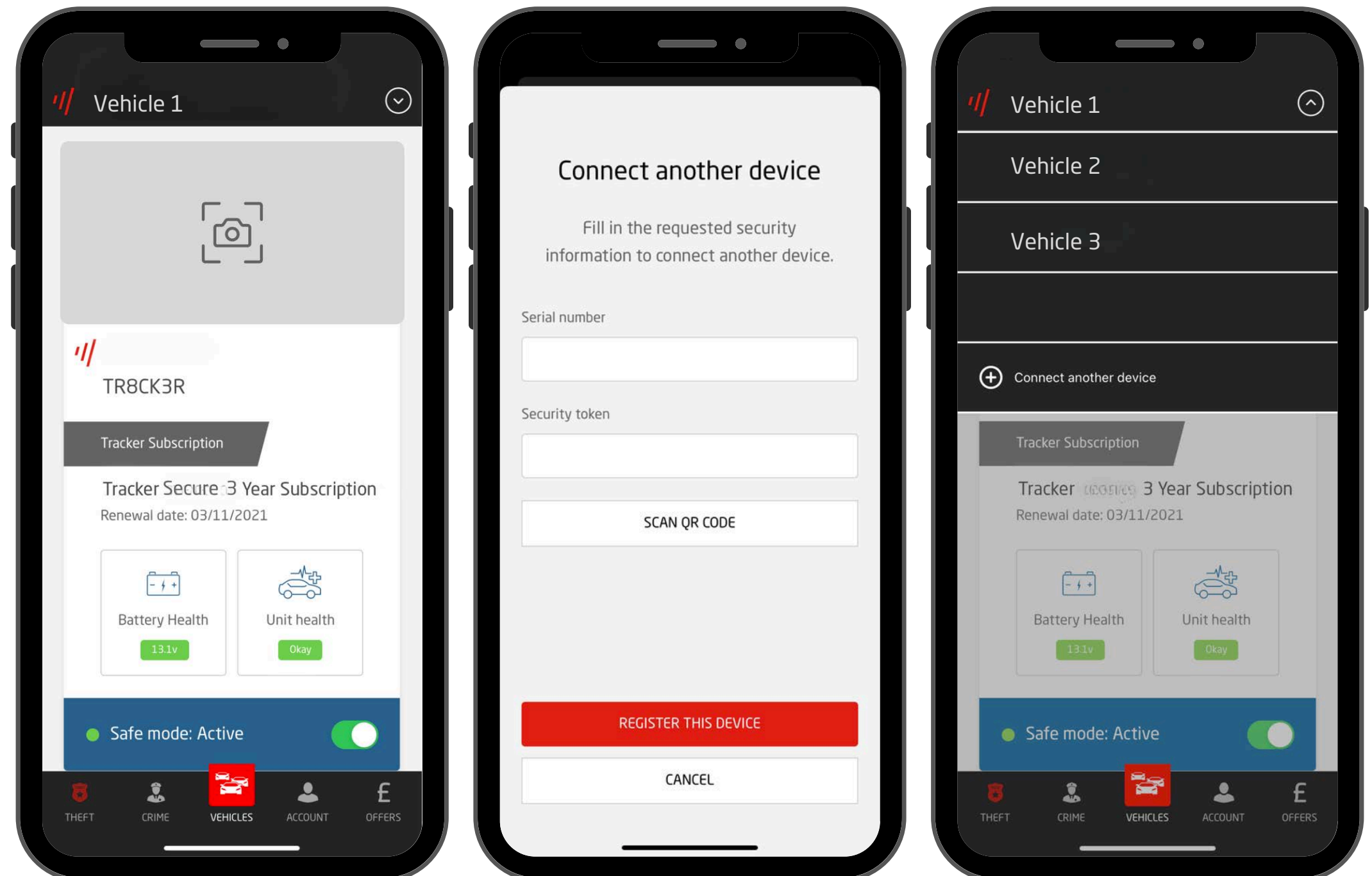

# Multi-Vehicle



## How to switch between vehicles

1. Use the  drop down arrow in the right hand corner of the screen to show all vehicles registered within the app
2. Select vehicle that you would like to view within the app
3. You will then be switched to the selected vehicle

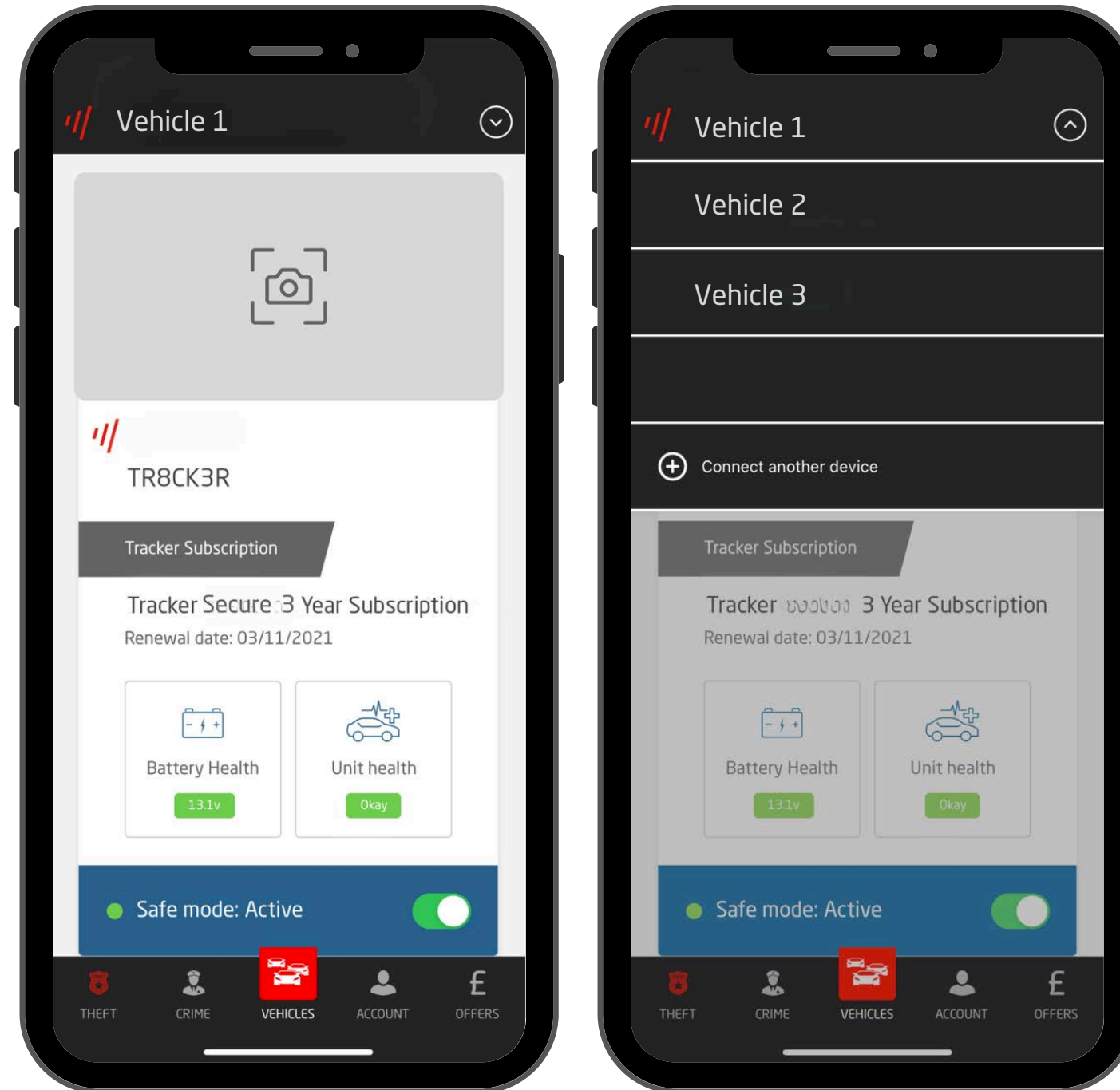
**Please note:** Safe Mode activations and Geofences do not transfer between vehicles. These need to be set per vehicle



## How to add additional vehicles

1. Use the  drop down arrow in the right hand corner of the screen to show all vehicles registered within the app
2. Select  Connect another device at the bottom of the drop down menu
3. Enter the **Serial Number** and **Security Token** of your second device
4. Select **Register This Device**

# Geofence Management

As an additional security layer, you can set multiple Geofence Areas by defining custom perimeters such as your home and work. If your vehicle breaches an activated perimeter, you will receive an instant alert

## How to set a Geofence:

1. Select **Geofence Management** within Vehicles
2. Select **ADD A GEOFENCE**
3. Use your current location or use the search bar to search for a location that you want to set a geofence around
4. Swipe the Radius toolbar up to enter a **Geofence Name** e.g. Home or Work
5. Select **SAVE** to set the Geofence

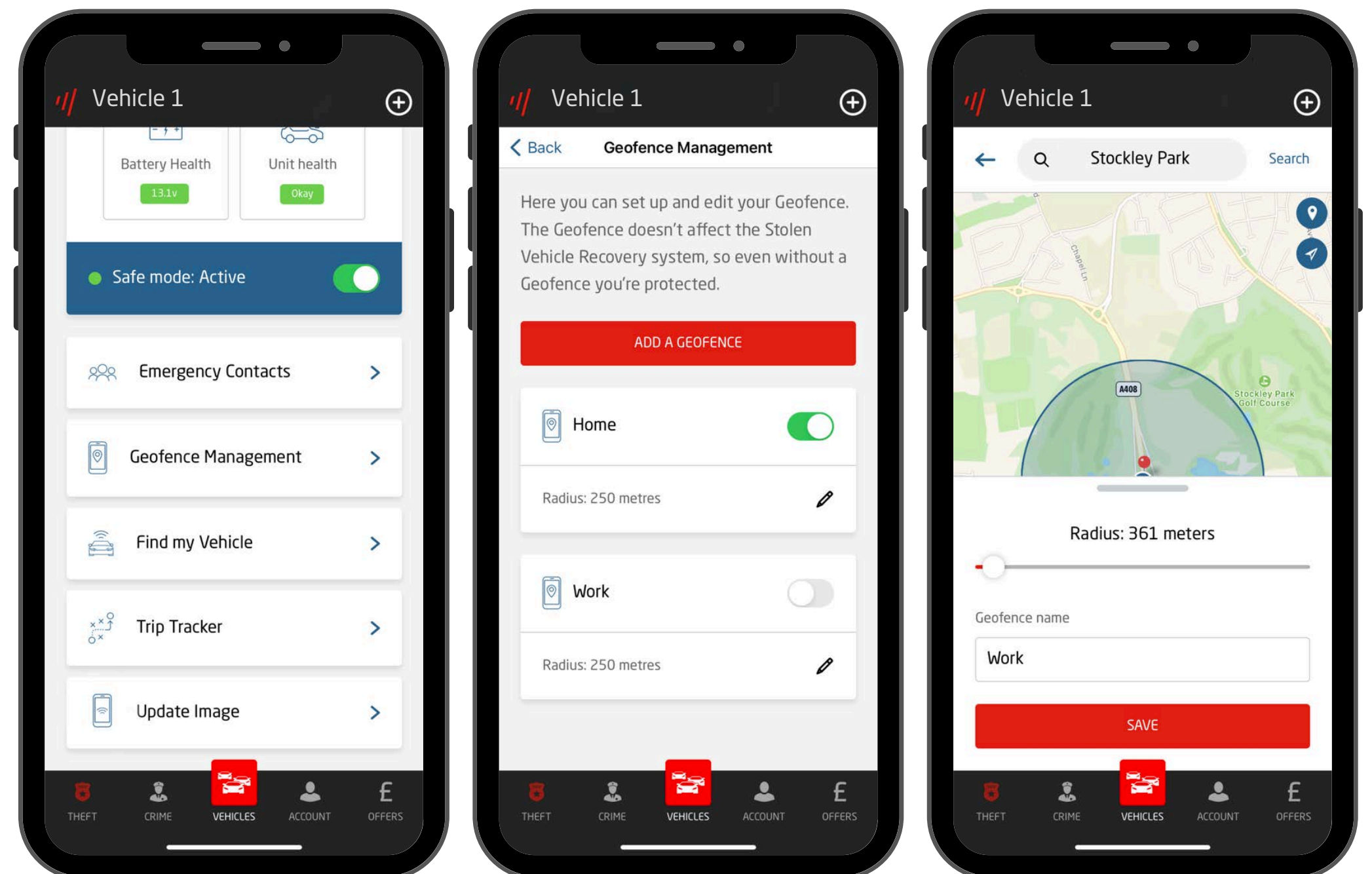

# Geofence Management

## Managing your Geofences

- You can view all of your saved Geofences within Geofence Management

- To activate or deactivate a Geofence slide the toggle on and off

Activated  Deactivated

- To remove a Geofence, swipe the Radius toolbar up and select **REMOVE GEOFENCE**

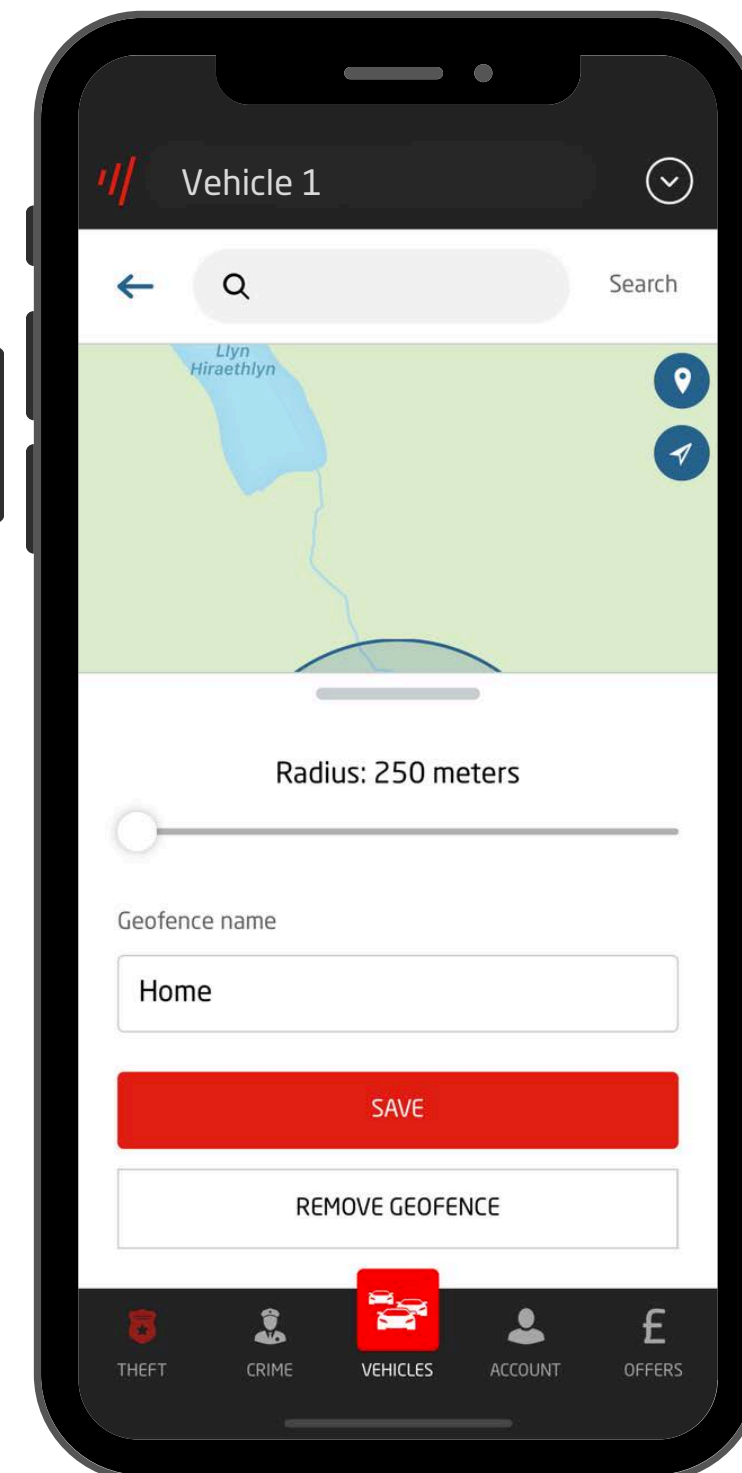
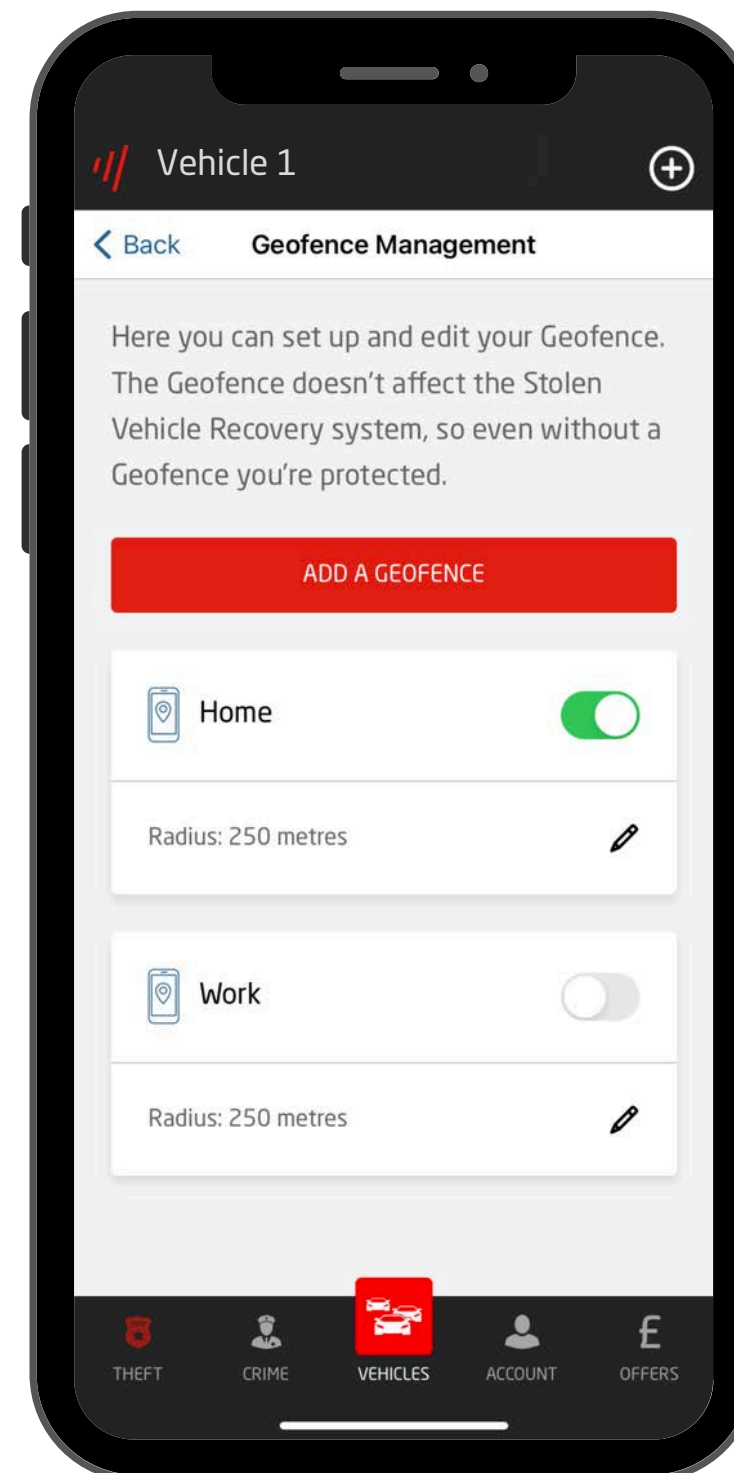

# Emergency Contacts

Be sure to provide at least two Emergency Contacts that are available in the unfortunate event of theft

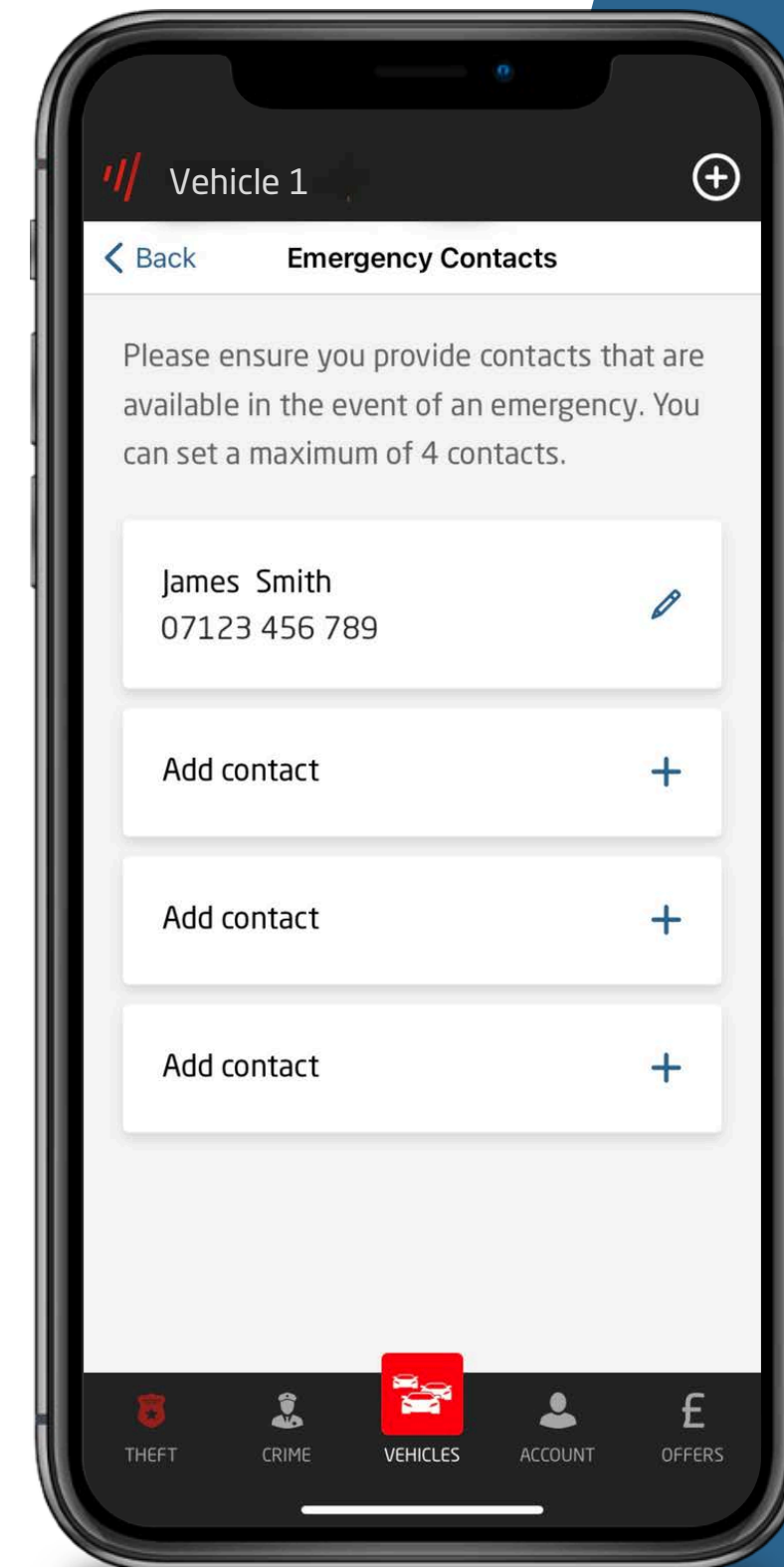

# Trip Tracker

All your travels are tracked and documented within the Tracker Touch app.

Trip Tracker allows you to view and share the routes you've taken, along with review detailed information of your trips, such as distance and time.

For a calendar view of your trips, select **CHOOSE A DATE**. All days shown in a red circle indicate a day that a trip has been made.

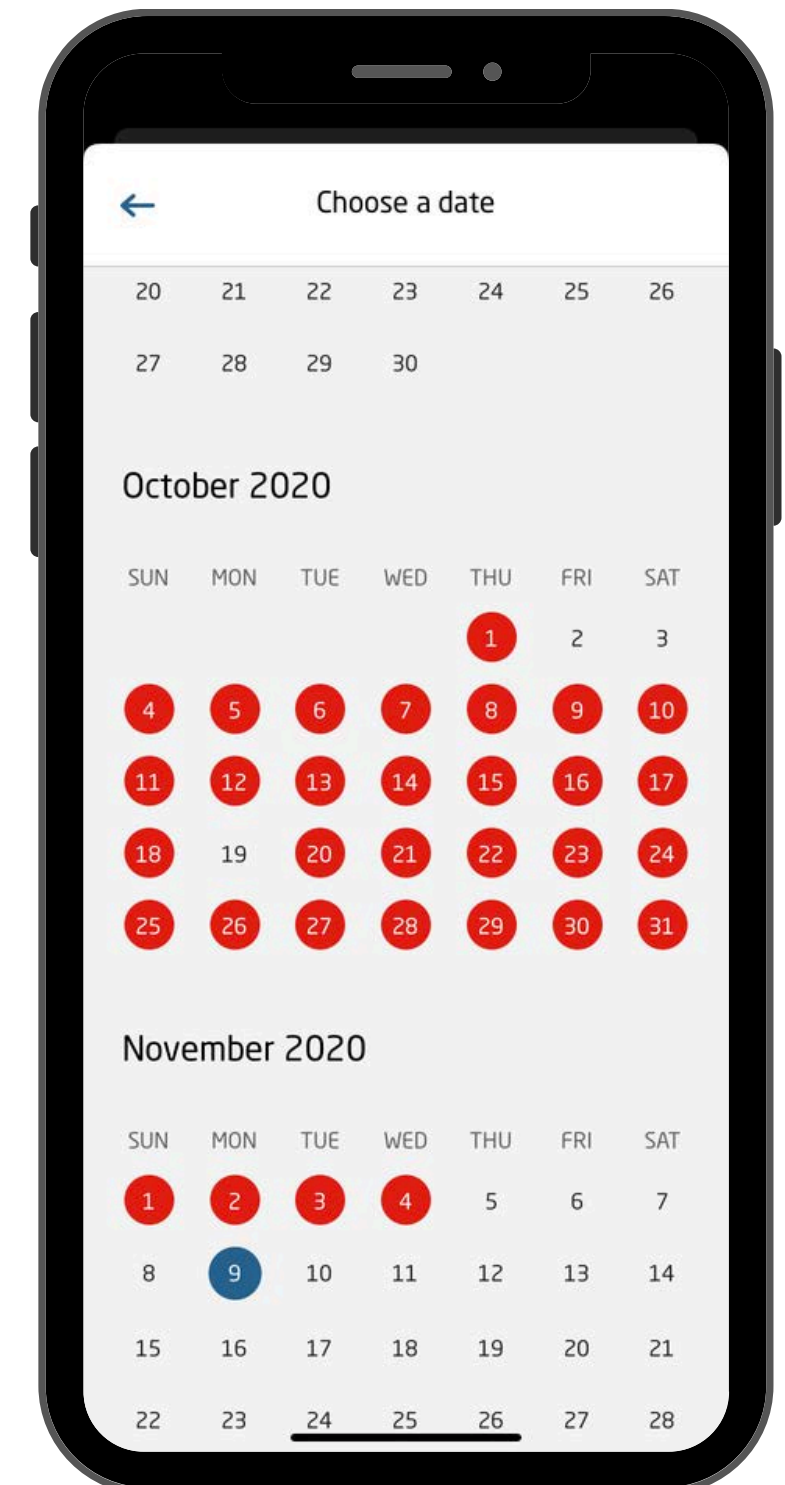
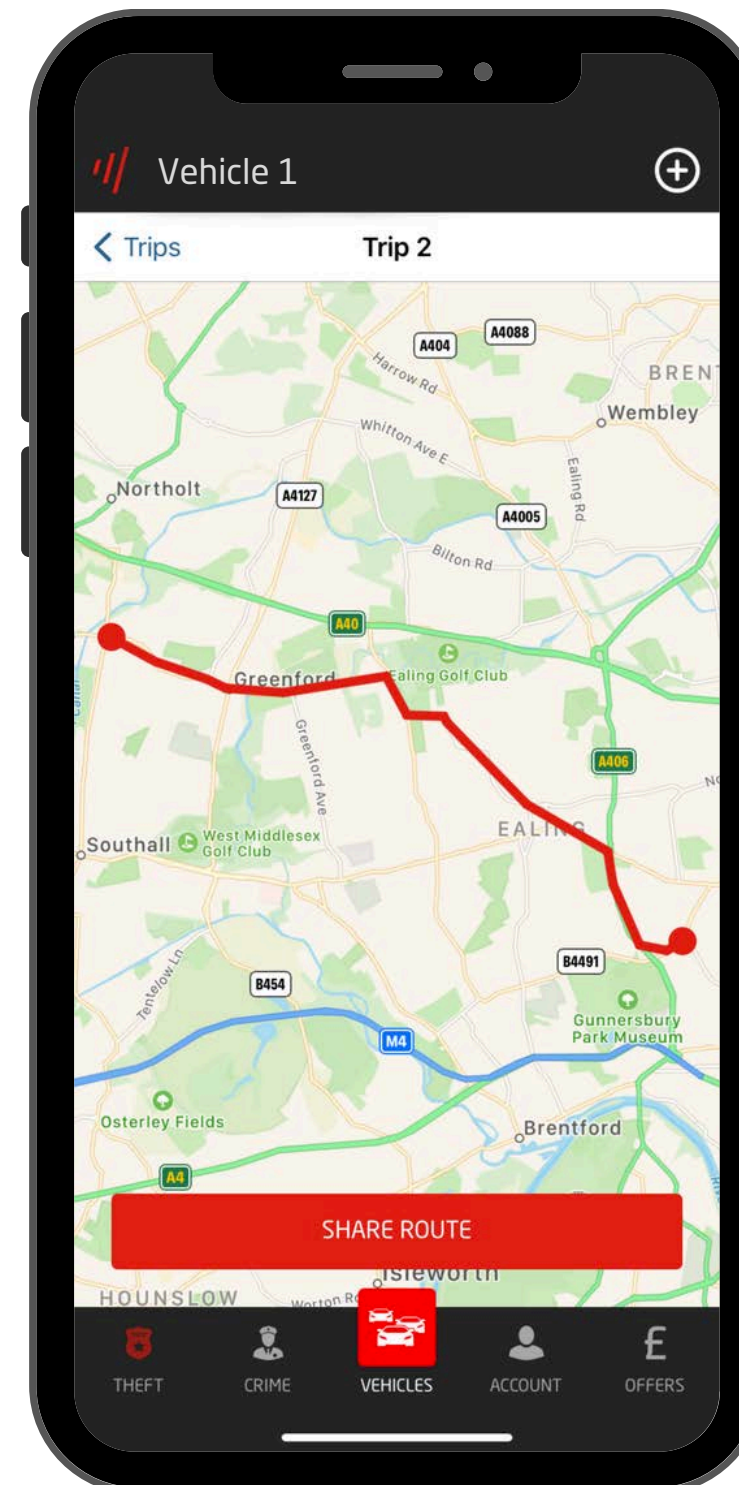
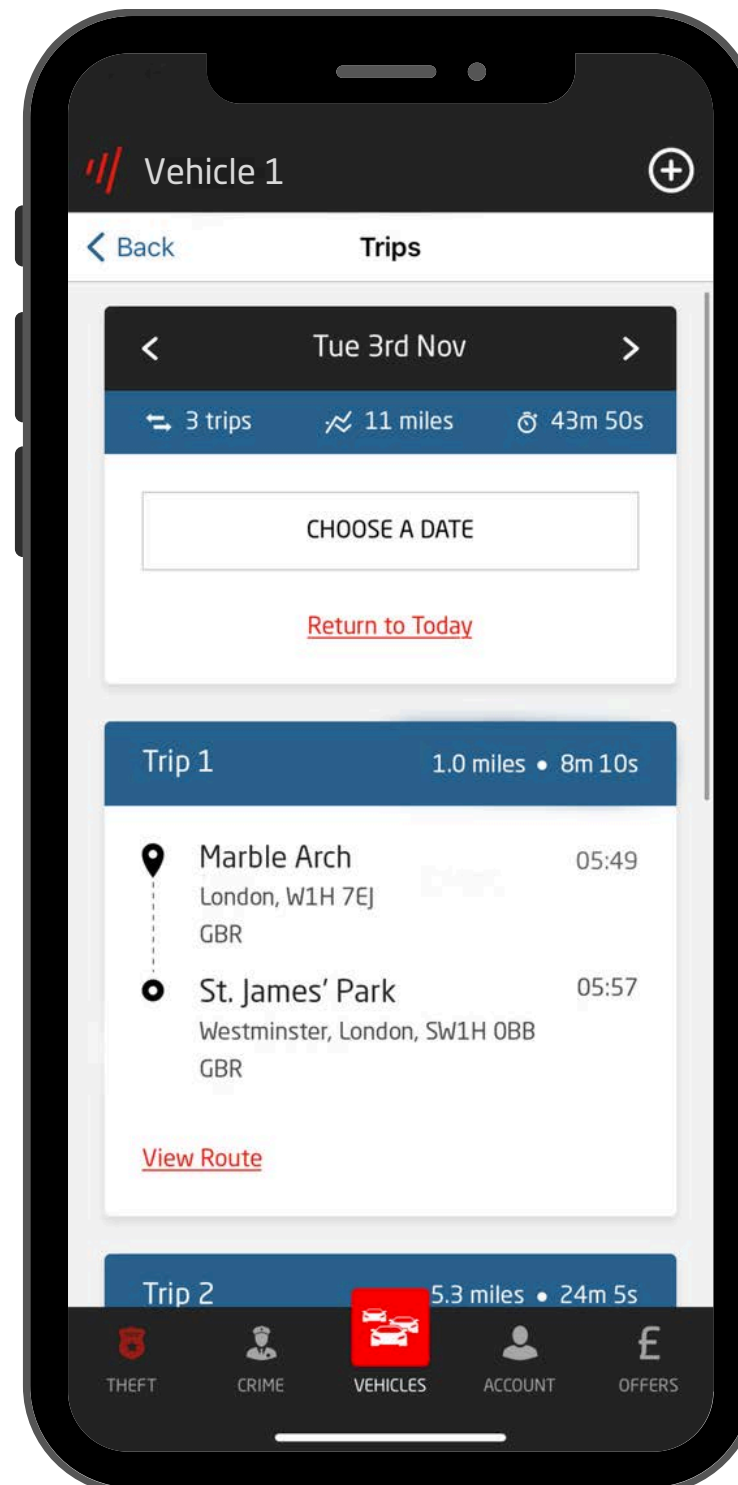

# Report Theft

In the unfortunate event of theft, you can call Tracker directly from your Tracker Touch app to report the theft.

Please ensure you follow these steps when reporting a theft:

1. Immediately report the theft to the police
2. Obtain a Crime Reference Number
3. Call Tracker to report the theft

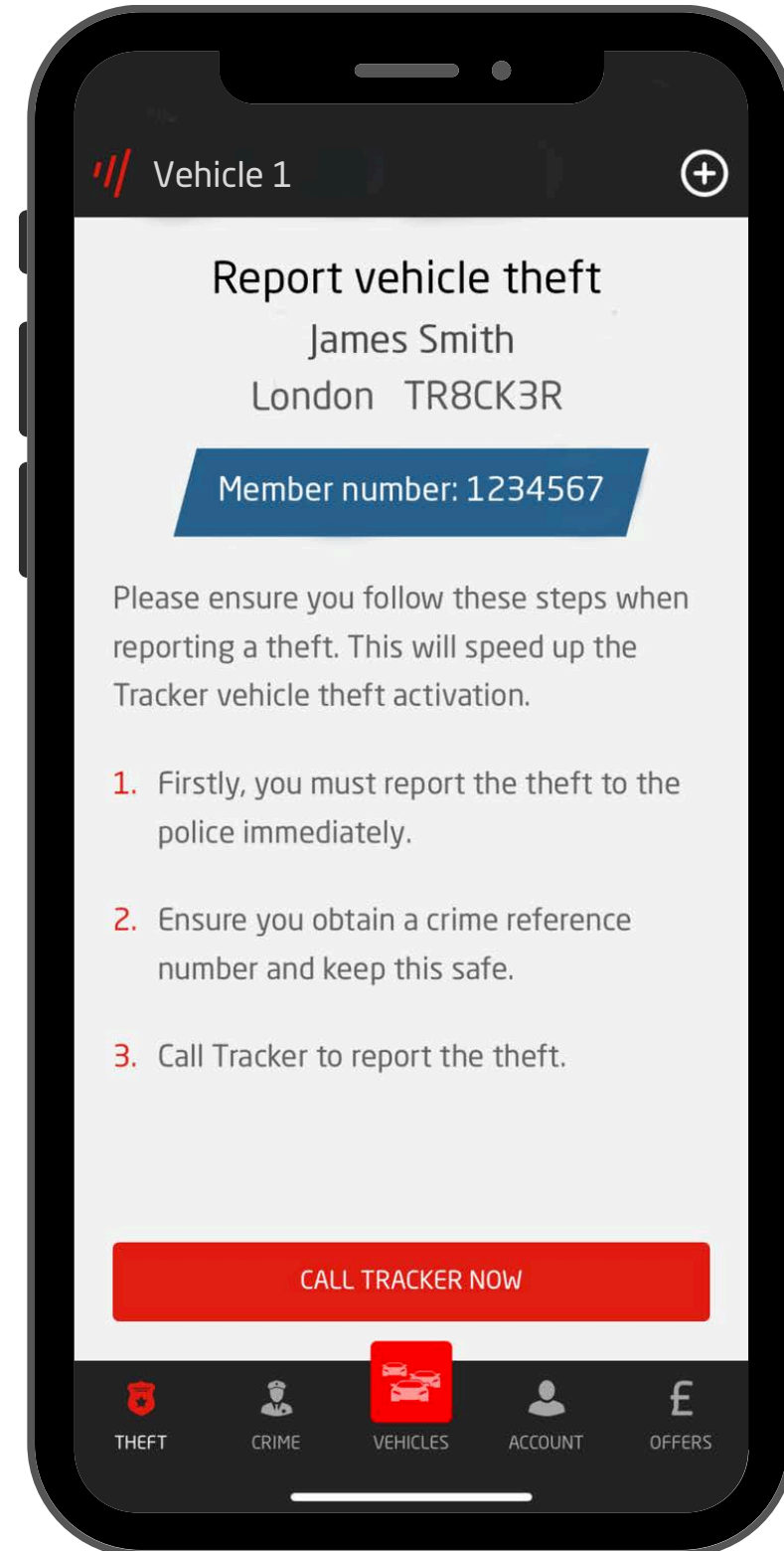

# Crime Area

Learn the crime rating of an area before you park your vehicle.

You can view the crime rating of where you are currently parked using your current location or you can search for a location before setting off to the destination.

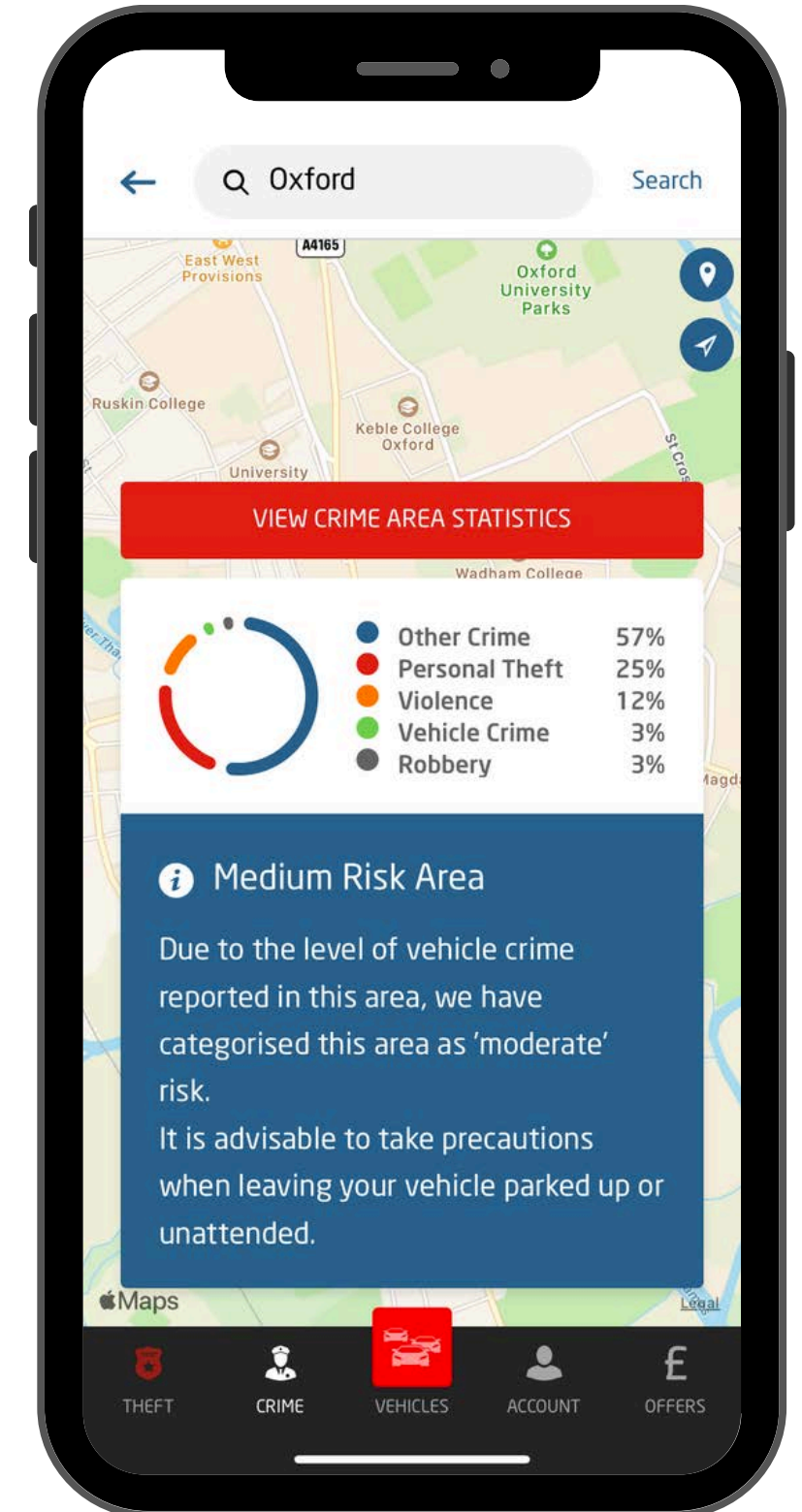

# My Account

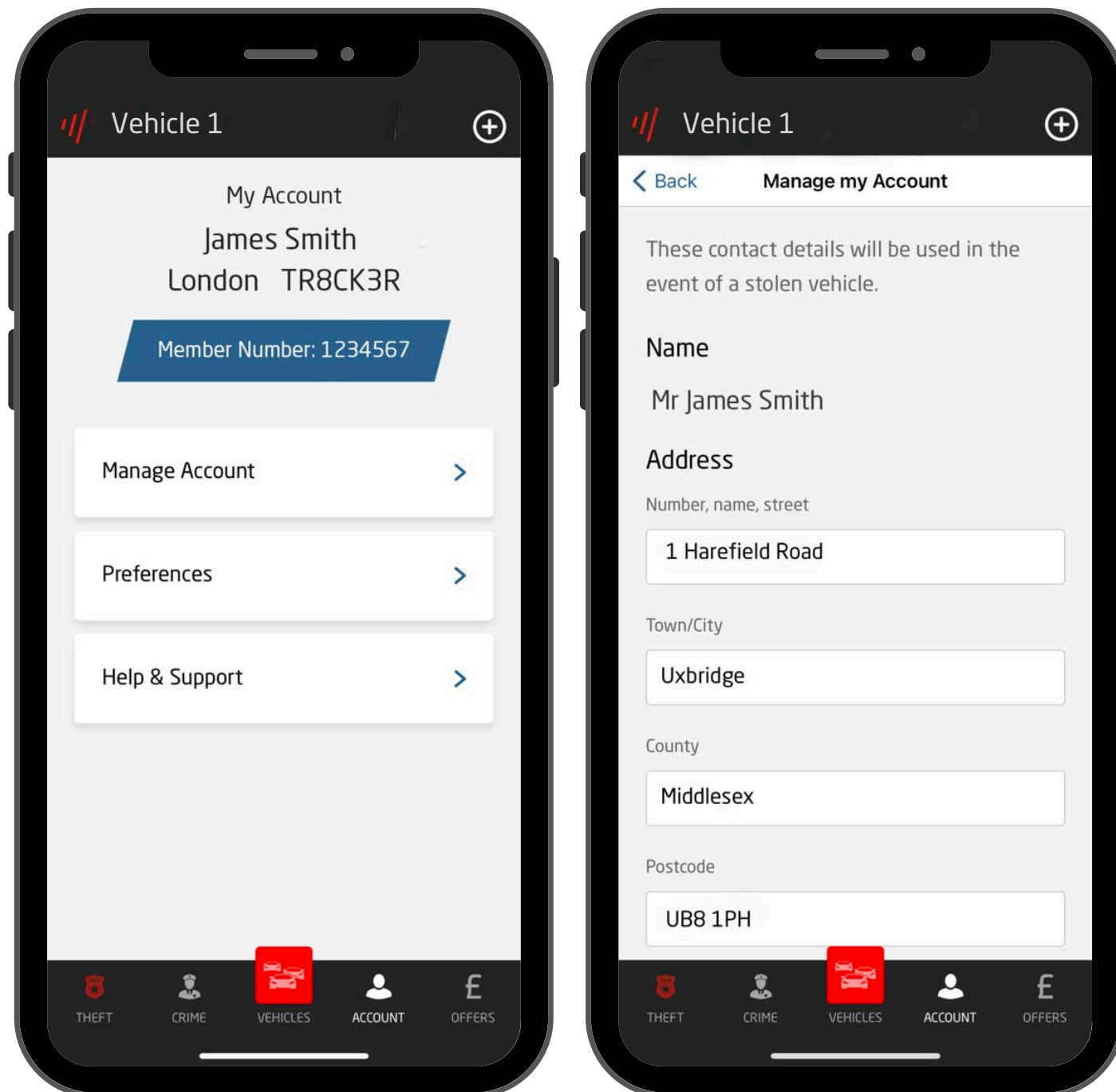

## Manage My Account

You will be able to update your contact details within **Manage My Account**.

Be sure to keep your email address up to date as we use this to send you important communications regarding your device and Tracker Account.

# Offers



# Frequently Asked Questions

## Tracker Product & Service

Tracker<sup>TM</sup>

# Frequently asked questions

## How do I know my Tracker is working?

The technician will test the Tracker system at the time of installation. The Tracker system gives a regular 'proof of life' every 28 days which we receive provided the system is in VHF coverage.

## When should I have my Tracker system re-tested?

### The Tracker system should be tested:

- After the vehicle has been repaired following an accident
- Following major alterations, particularly to the electrical system
- After theft recovery
- When the unit is 3 years old

## Will my Tracker system work in Europe?

Tracker S5+ Immobiliser provides full European coverage.

## Do you offer Theft Recovery Service in Europe?

No, this service is only available in mainland Great Britain.

## Is my Tracker system battery covered under warranty?

If the vehicle battery is disconnected or goes flat, the Tracker device will operate for a limited time using its internal non-rechargeable backup battery. This battery is designed for one-time use and, once depleted, the device will no longer send alerts if the vehicle battery is compromised.

If the vehicle battery is disconnected for servicing or modifications, this should be kept to a minimum.

**Please note:** the internal backup battery is not covered by the 12-month unit warranty, and a call-out charge applies for inspection and battery audit.

## Can I order replacement Tracker Driver Tags?

Yes. You can order up to five replacement Driver Tags, and charges apply.

**Important:** If your tag is lost or stolen, contact the **Customer Service Team** immediately on **0808 5090909** to purchase a replacement.

## What happens if my vehicle battery is disconnected?

If your vehicle battery is disconnected, the Tracker system will generate an alert. To avoid false alerts, please inform Tracker before disconnecting the battery. If the vehicle battery is disconnected, the Tracker device will rely on its internal non-rechargeable backup battery for a limited time. How long it operates depends on how often and for how long the vehicle battery has been disconnected during the product's lifetime, such as during servicing or theft. If the backup battery becomes depleted, a **chargeable service call** will be required.

**Please note** that if the internal battery is not maintained, the system may no longer be able to send a main battery disconnect alert.

## Does my Tracker system require a subscription?

Yes, customers are required to have a fully paid subscription in order to be covered by the Tracker service.

# Frequently asked questions

## How can I transport my vehicle without triggering the Tracker system?

If you know your vehicle may trigger a false movement alert during transport, please call **Tracker** on **0808 509 0909** in advance. We can suspend all or part of the Tracker service for an agreed period.

## Can my Tracker system be transferred from one vehicle to another?

No. For security reasons and to avoid false alarms, the Tracker system remains with the original vehicle for its lifetime. When you sell the vehicle, the new owner can continue to benefit from the Tracker system by registering with Tracker Network and paying the applicable registration and subscription fee. **Please note:** the Tracker subscription cannot be transferred to the new vehicle owner.

## What should I do with my Tracker registration document?

When you receive your registration document, please check that all personal and vehicle details are correct. If any changes are needed, contact our **Customer Service Team** on **0808 509 0909**. Keep the document in a safe place and do not store it in your vehicle.

## What do we mean by immobilisation of your vehicle?

Depending on the vehicle type and installation method, immobilisation can work in different ways.

Examples include:

- The vehicle may start, but the vehicle will not be able to shift into Drive
- The vehicle may be prevented from starting altogether

## What to do when your vehicle is booked in for Service/Repair:

- ✓ When servicing your vehicle, advise the technician to keep vehicle battery disconnection time to a minimum.
- ✓ Please inform the technician that an immobiliser is fitted. **To prevent the vehicle from being immobilised, ensure the car key and Driver Tags are kept together** when starting the vehicle.
- ✓ If your vehicle battery is disconnected, an alert will be generated. You must inform Tracker prior to battery disconnection to avoid any false alerts.
- ✓ If the non-rechargeable back-up battery becomes flat a chargeable service call will be required.

## If you sell your vehicle

If you sell, transfer or dispose of your vehicle, please complete the tear-off section on your registration document and post it to us at:

**Tracker™ Network (UK) Ltd**  
The Atrium,  
1 Harefield Road,  
Uxbridge,  
Middlesex,  
UB8 1PH

The Tracker device stays with the original vehicle for its lifetime, it is not transferable from vehicle to vehicle.

Once you've sold your vehicle, the new owner can register the system in their name by simply paying a registration and a subscription fee.

**Call 0808 509 0909 to register today.**

**Tracker™ Network (UK) Ltd.**  
**The Atrium, 1 Harefield Road, Uxbridge, Middlesex, UB8 1PH**  
**0808 509 0909 [www.tracker.co.uk](http://www.tracker.co.uk)**

Tracker™ Network (UK) Limited. All rights reserved. Tracker™ and the Tracker™ logo are registered trademarks of Tracker™ Network (UK) Limited © 2026. Tracker™ reserve the right to alter and modify product specifications and pricing without prior notification.

Tracker™ 